

FINSBURY

water filters

Disruptor™ filtration technology reduces more impurities than any other conventional water filter.



Easy to install
Fits most kitchen taps
Long lasting cartridges

countertop **filter**



- suitable for VOL filtration units
- reduces particulates
- reduces dirt, sediment and rust
- reduces bacteria
- improves taste
- reduces odours
- reduces chlorine
- reduces particulates
- reduces giardia and cryptosporidium

WATERCO
water, the liquid of life

www.waterco.com

Contents

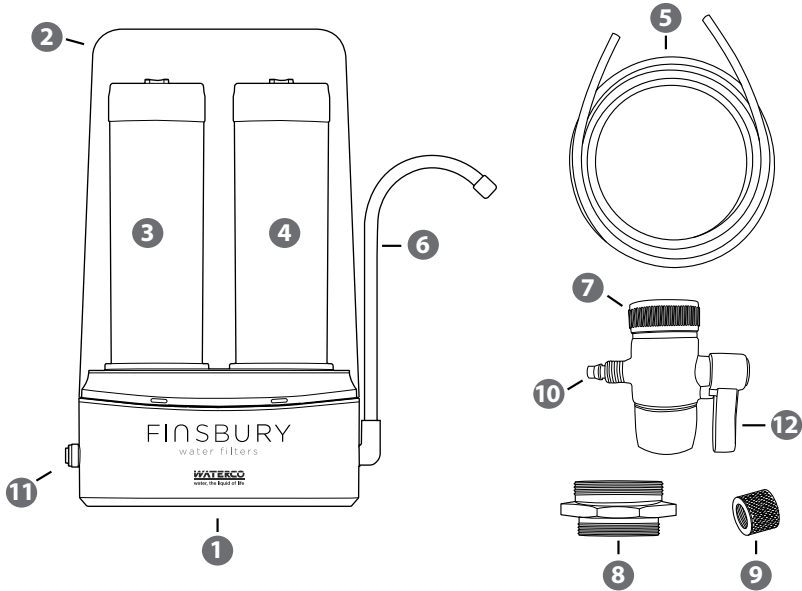

- | | |
|---------------------------------|-----------------------------|
| 1. two stage filtration unit | 7. chrome plated faucet end |
| 2. filter cover | 8. hexagonal thread adapter |
| 3. PP sediment cartridge filter | 9. round threaded nut |
| 4. disruptor cartridge filter | 10. inlet spout nipple |
| 5. hose | 11. filter unit inlet |
| 6. chrome plated tap spout | 12. control valve |

Product technical specifications

Flow rate	1.8L/min
Max. pressure	400 kPa / 60 psi
Filter capacity	3000L
Water source	municipal water
Filter life	6 months*



The water source should be municipal water. Please do not use groundwater for filtration to avoid reducing filtration effectiveness and shorter filter service life. Tank water may require a sediment pre-filter unit attached to tank. Please contact us for more information.

Installation

Connecting counter top filter

- 1 Unscrew the end cap on the end of your faucet.
- 2 If the thread on the end of your faucet is on the inside, screw in the wider diameter of the supplied hexagonal thread adapter (8) into faucet end and hand tighten. Otherwise proceed to step 3.
- 3 Screw on the chrome plated faucet end (7) either onto the hexagonal thread adapter or directly onto faucet end. Hand tighten.
- 4 Unscrew the round threaded nut (9) off the inlet spout on the chrome plated faucet end and attach to one end of the hose (5), ensuring the open end of the nut is facing towards faucet end.
- 5 Push hose firmly onto inlet spout nipple (10) until it is sitting flush against thread. secure by hand tightening the round threaded nut.
- 6 Remove blue locking clip from the filter unit inlet (11) and connect other end of hose into the filter unit inlet hole until it stops. Apply the blue locking clip into the inlet to secure hose.

Faucet set-up

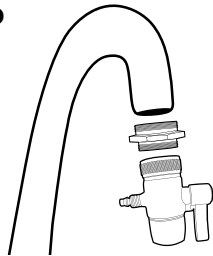

internal thread set-up

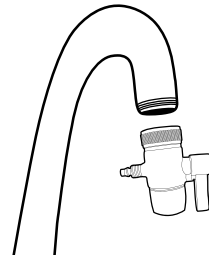

external thread set-up

Operating instructions

- 7 When the control valve (12) on the chrome plated faucet end is in the down position, the water from the faucet will come directly from the faucet (unfiltered).
- 8 When the control valve is rotated 90 degrees, the water will pass through the two stage filtration unit. Check for leaks and adjust if necessary.
- 9 Let the system run for a few minutes to flush the filter cartridges.
- 10 Allow the system to stand for 2 to 3 hours and then flush again for several minutes. The system now is operational. Water flow reduction usually indicates clogging of filter cartridges. Filter cartridge should be changed based on filter changing instructions. The service life will vary due to water quality and usage.

Filter replacement

- 1 To remove the filter:** remove filter cover. Turn filter 1/4 turn to the right. The filter will rotate away from the filter head. Pull the filter upwards to remove.
- 2 To replace the filter:** Insert filter into the filter head. Turn filter 1/4 turn to the left until it stops. The bottom surface of the filter will be flush with the bottom of the filter head when fully installed. Replace filter cover.



Important notes

- This system can only filter water between 4 - 38 °C. Do not filter hot water.
- In the beginning, the filtered water may have small black carbon particles released from the filter. This is normal with no negative health effects. Use this preliminary dark water for watering or cleaning.
- If the filtered water develops an odour, please replace the filter immediately.
- Please store spare filters in a cool and dry place.
- If required, plumbing tape may be used to secure water tight fitting and prevent possible leaking.
- * In order to maintain optimum filtration, it is recommended to replace filter after 3000 Litres or 6 months. Because water quality and volume of consumption varies, filter service life changes.

Warranty

The Finsbury Countertop Water Filter system is warranted to be free from defects in material and workmanship for a period of 3 years. Warranty on consumable products such as filters does not apply.

The warranty is expressly limited to the replacement/repair of any part or parts proving defective providing the installation and operation has been fully in accordance with these instructions and all relevant plumbing codes and standards. The warranty shall be voided by mechanical damage caused during installation or neglect. Failure to utilise Finsbury Water Filter branded filters will result in your warranty being null and void. Failure to comply with scheduled filter changes may result in your warranty being void.

OFFICES - AUSTRALIA

NSW - Sydney
(HEAD OFFICE)
Tel : +61 2 9898 8686

VIC/ TAS - Melbourne
Tel : +61 3 9764 1211

WA - Perth
Tel : +61 8 9273 1900

QLD - Brisbane
Tel : +61 7 3299 9900

SA/ NT - Adelaide
Tel : +61 8 8244 6000

ACT Distributor
Tel : +61 2 6280 6476

OFFICES - OVERSEAS

Waterco USA
Augusta, USA
Tel : +1 706 793 7291

Waterco Canada
Boucherville, QC, Canada
Tel : +1 450 748 1421

Waterco (Europe) Limited
Sittingbourne, Kent, UK
Tel : +44(0) 1795 521 733

Waterco (NZ) Limited
Auckland, New Zealand
Tel : +64 9 525 7570

Waterco (C) Limited
Guangzhou, China
Tel : +8620 3222 2180

Waterco (Far East) Sdn. Bhd.
Selangor, Malaysia
Tel : +60 3 6145 6000

PT Waterco Indonesia
Jakarta, Indonesia
Tel : +62 21 4585 1481

Waterco International Pte Ltd
Singapore
Tel : +65 6344 2378